

10K

THREADED BALL VALVE (Full Bore)

Fig. 10FCT

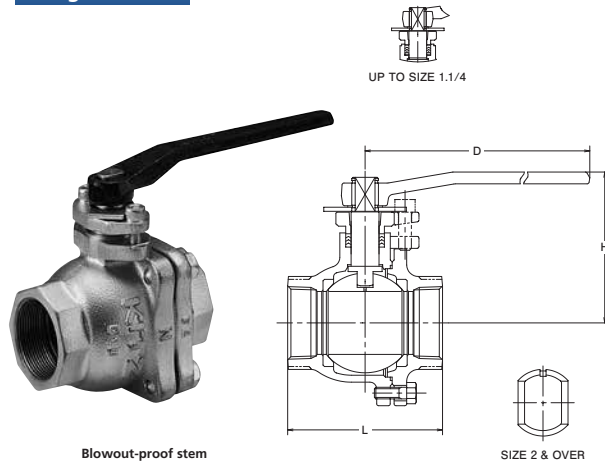

Materials

Parts	Material	JIS Spec.
Body	Cast Iron	FC200
Body cap	Cast Iron	FC200
Stem	Stainless Steel	SUS403
Ball	Stainless Steel	SCS13A or SUS304 or SUS304TP
Grand packing	PTFE	
Gasket	PTFE	
Ball seat	PTFE	
Cap bolt	Carbon Steel	
Handle	Ductile Iron	FCD400-15

Design Specifications

Items	
Shell wall thickness and general valve design	KITZ Standard
Face-to-face dimensions, end-to-end dimensions	KITZ Standard
Threaded ends	JIS B0203

For Pressure-Temperature Ratings, refer to individual catalog(No.E-201).

Dimensions

Valve Size	B	3/8	1/2	3/4	1	1 1/4	1 1/2	2	2 1/2	3	mm
L Face-to-face	A	10	15	20	25	32	40	50	65	80	
H Height		72	80	85	95	120	120	140	160	182	
D Handle		71	102	105	125	130	115	120	155	165	
		130	130	130	160	160	230	230	400	400	

10K

BALL VALVE (Full Bore)

Fig. 10FCTB

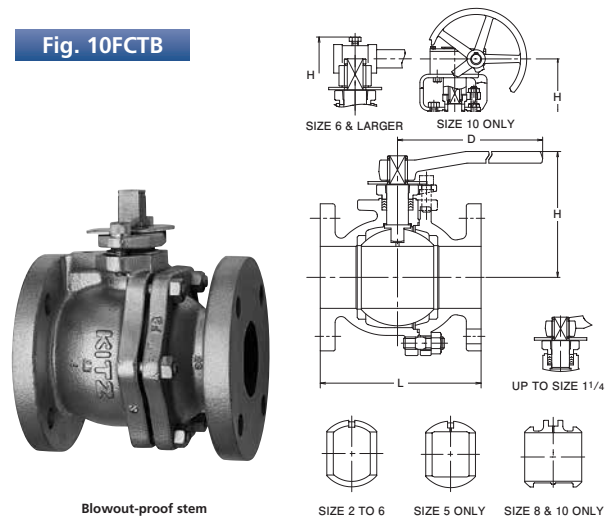

Materials

Parts	Material	JIS Spec.
Body	Cast Iron	FC200
Body cap	Cast Iron	FC200
Stem	Stainless Steel	SUS403
Ball	Stainless Steel	SCS13A or SUS304 or SUS304TP
Grand packing	PTFE	
Gasket	PTFE	
Ball seat	PTFE	
Cap bolt	Carbon Steel	
Handle	Ductile Iron	FCD400-15

Design Specifications

Items	
Shell wall thickness and general valve design	KITZ Standard
Face-to-face dimensions, end-to-end dimensions	KITZ Standard
End flange dimensions, gasket contact facing	JIS B2239 10K

For Pressure-Temperature Ratings, refer to individual catalog(No.E-201).

Dimensions

Valve Size	B	1/2	3/4	1	1 1/4	1 1/2	2	2 1/2	3	4	5	6	8	10	mm
L Face-to-face	A	15	20	25	32	40	50	65	80	100	125	150	200	250*	
H Height		110	120	130	140	165	180	190	200	230	300	340	450	533	
D Handle		102	105	124	128	114	121	154	163	199	219	292	352	477	
		130	130	160	160	230	230	400	400	460	460	1000	1500	-	

\*Note: Gear Operated. Contact KITZ or KITZ distributors for details.